

NOTE:
 1.MATERIAL:
 1.1 MOLDING: LCP UL94 V-0;
 1.2 MID PLATE: STAINLESS STEEL;
 1.3 TERMINAL: COPPER ALLOY C2680;
 1.4 SHELL: SUS304-H,T=0.30±0.03mm;
 2.PLATING:
 2.1 TERMINAL: OVERALL PLATING Ni BASE 50u"Min, PLATING Au 1u"Min

IN CONTACT AREA, PLATING Sn 50u"Min IN THE WELDING AREA

2.2 SHELL: OVERALL PLATING Ni 50u"Min;
 2.3 MID PLATE: CLEANING;
 3.MECHANICAL:
 3.1 INSERTION: 5~20N;
 3.2 EXTRACTION: 8~20N AFTER TEST;
 3.3 DURABILITY: 10000 CYCLES;
 4.ELECTRICAL:
 4.1 CURRENT: VBUS 3A/2 = 1.5A PerPin; GND 3A/2 = 1.5A PerPin;

Others 0.25A Min;

4.2 VOLTAGE: 20 V Max;
 4.3 WITHSTANDING VOLTAGE: 100V AC;
 4.4 CONTACT RESISTANCE: 40mΩ MAX;
 4.5 INSULATION RESISTANCE: 100MΩ Min;
 5.ENVIRONMENTAL
 5.1 TEMPERATURE RANGE -25°C ~ +85°C;

A5	CC1	B12	GND
A9	VBUS	B9	VBUS
A12	GND	B5	CC2
PIN	SIGNAL NAME	PIN	SIGNAL NAME

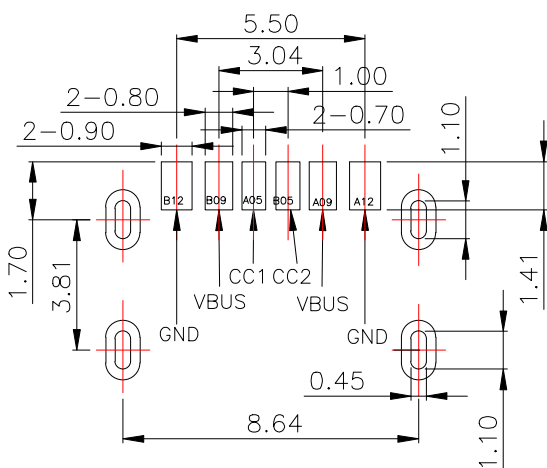
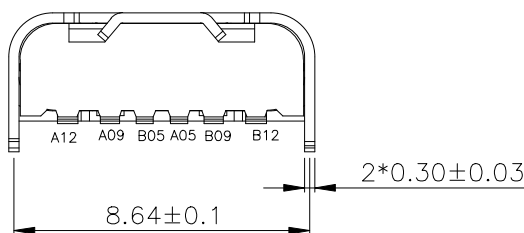
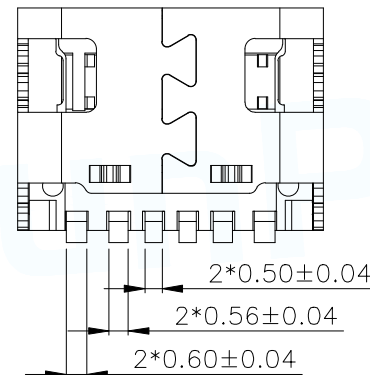
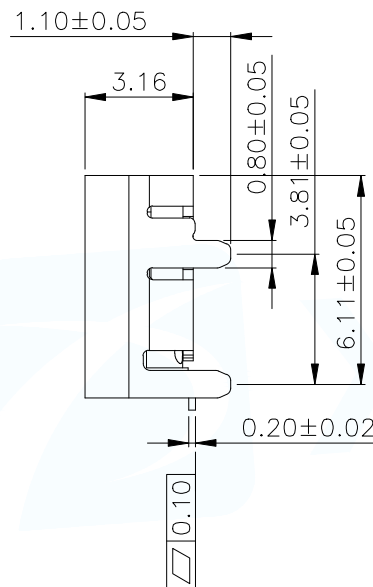
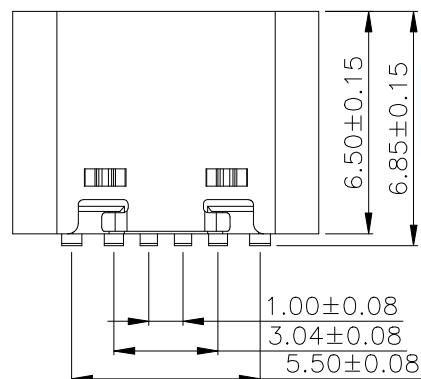

RECOMMENDED P.C.B. LAYOUT
 TOLERANCE UNSPECIFIED ±0.05mm

4	SHELL	STAINLESS STEEL SUS304	Ni/SN Plated	1PCS
3	MID PLATE	STAINLESS STEEL SUS301	---	1PCS
2	CONTACT	COPPER ALLOY C2680 EH	C2680 EH (SEE TABLE)/Ni50u"/SN 80u" Plated	1SET
1	HOUSING	HIGH TEMPERATURE PLASTIC	BLACK	1PCS
NO.	DESCRIPTION	MATERIAL	REMARKS	QTY

MANUFACTURE DWG			东莞市讯普电子科技有限公司 DongGuan XunPu Electronics Co.,Ltd	
UNLESS OTHERWISE SPECIFIED TOLERANCES			TITLE: TYPE-C 6Pin 板间距6.50mm SMT	
DECIMALS:	ANGLES:	PAR	TYPE-C-250-BRP6L65	
.X:±0.30	.X':±3°	DWN		
.XX:±0.20	.XX':±2°	CHKD		
.XXX:±0.10		APVD		
CUSTOMER COPY		SCALE1:1	UNIT:MM	
		SIZE:A4	SHEET:1F1	REV:A