

剖视“A-A”  
比例 1:1

NOTE:

- MATERIAL SPECIFICATION:
  - HOUSING: HIGH TEMPERATURE RESISTANT PLASTIC, UL94 V-0.
  - TERMINAL: COPPER ALLOY
  - MID PLATE: STAINLESS STEEL
  - FRONT SHELL: STAINLESS STEEL
- PLATING SPECIFICATION:
  - TERMINAL:
    - Ni 50u" MIN. UNDER PLATED OVER ALL.
    - Au PLATED ON THE FUNCTIONAL AREA OF CONTACT.
    - CONTACT FUNCTIONAL AREA PLATED : Au G/F
    - CONTACT SOLDER AREA PLATED : Au G/F
  - FRONT SHELL:
    - Ni 30u" MIN. UNDER PLATED OVER ALL.
  - MID PLATE
    - CLEAR ONLY
- MECHANICAL PERFORMANCE,
  - INSERTION FORCE: 0.5~2.0kgf.
  - REMOVAL FORCE: 0.8kgf~2.0kgf.
  - DURABILITY: 10000 CYCLES.
- ELECTRICAL PERFORMANCE,
  - VOLTAGE RATING: 5 V DC/AC (RMS. max)  
CURRENT RATING: 3A  
1.5AMPS MIN FOR VBUS PIN,  
0.25 AMPS. FOR ALL OTHER CONTACT.
  - LLCR:
    - VBUS & GND PINS AND OTHER PINS: 40mA/PIN MAX.
    - SHIELD: 50mA/MAX.
    - LLCR MAX. CHANGE OF ALL PINS: 10mA.
  - INSULATION RESISTANCE: 100MΩ MIN
  - DIELECTRIC WITHSTAND VOLTAGE, AC 100V FOR 1 MINUTE.
- ENVIRONMENTAL PERFORMANCE:
  - OPERATING TEMPERATURE: -25°C~+85°C.
  - IR REFLOW:
    - THE PEAK TEMPERATURE ON THE BOARD SHALL BE MAINTAINED FOR 10 SECONDS AT 260°C.

MANUFACTURE DWG		东莞市讯普电子科技有限公司 DongGuan XunPu Electronics Co., Ltd	
UNLESS OTHERWISE SPECIFIED TOLERANCES			TITLE: USB CF 6PIN VERTICAL SMT
			PAR TYPEC-251LX-ECP6
DECIMALS:	ANGLES:		DWN
.X:±0.30	X':±10'		CHKD
.XX:±0.20	.X':±8"	APVD	SCALE 1:1 UNIT:MM
.XXX:±0.10	.XX':±5"	CUSTOMER COPY	SIZE:A4 SHEET:1F1 REV:A

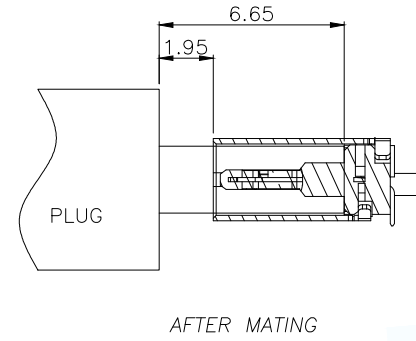
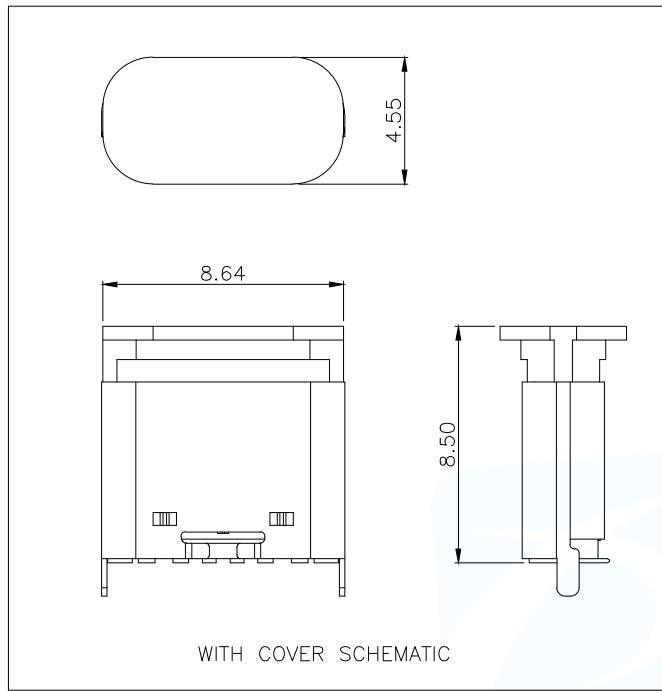

PIN ASSIGNMENTS

A5	CC1	B12	GND
A9	VBUS	B9	VBUS
A12	GND	B5	CC2
PIN	SIGNAL NAME	PIN	SIGNAL NAME

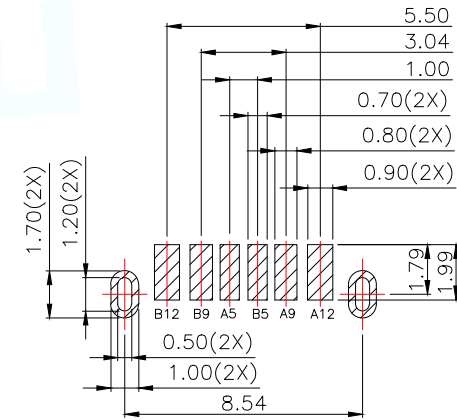

THICKNESS 1.00±0.10MM;DEFAULT TOLERANCE:±0.05

MANUFACTURE DWG		东莞市讯普电子科技有限公司 DongGuan XunPu Electronics Co.,Ltd	
UNLESS OTHERWISE SPECIFIED TOLERANCES			TITLE: USB CF 6PIN VERTICAL SMT
			PAR TYPEC-251LX-ECP6
DECIMALS:	ANGLES:		DWN
.X:±0.30	X':±10°		CHKD
.XX:±0.20	.X':±8°	APVD	SCALE:1:1
.XXX:±0.10	.XX':±5°	CUSTOMER COPY	UNIT:MM
		SIZE:A4	UNIT:MM
		SHEET:1F1	REV:A

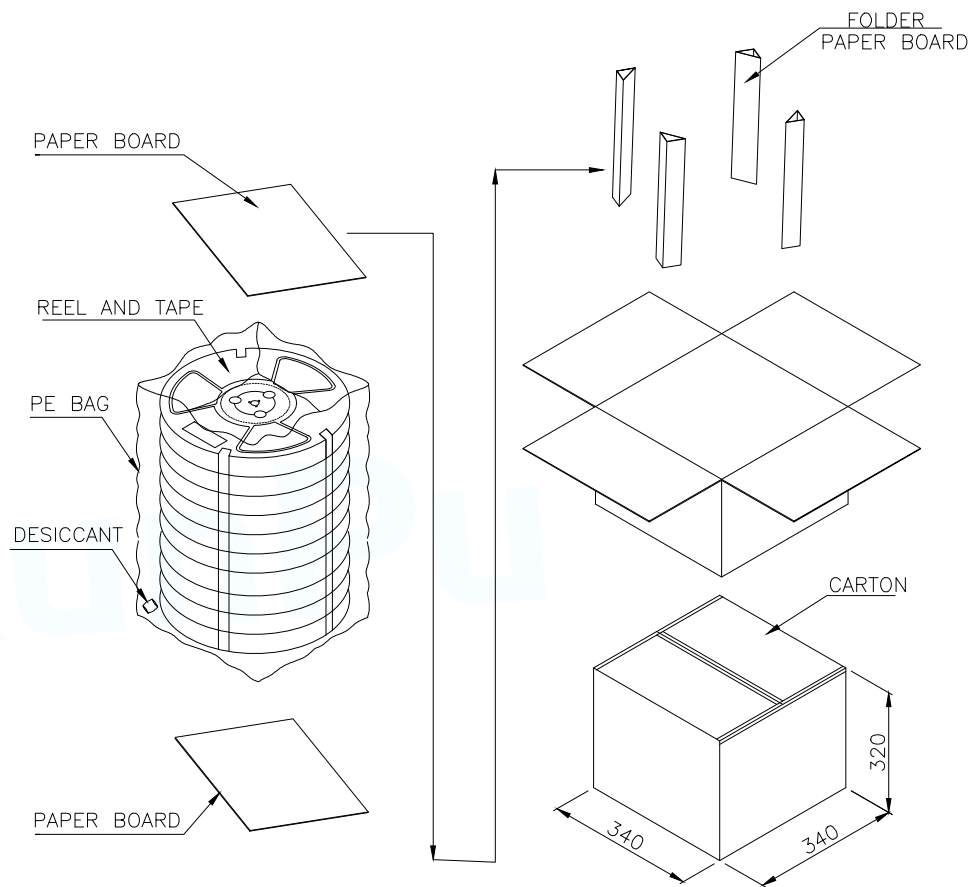
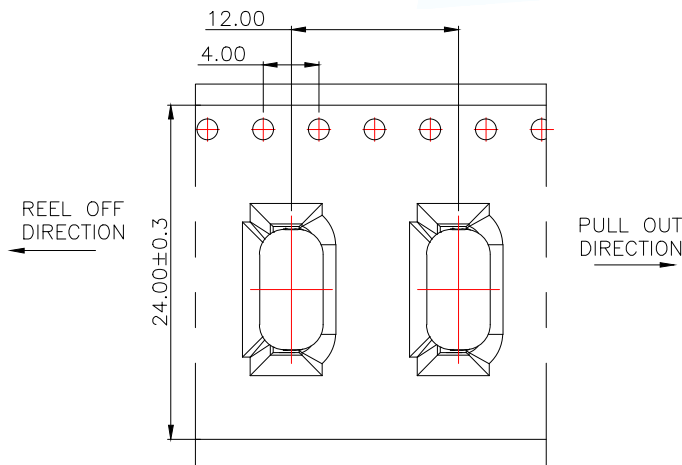
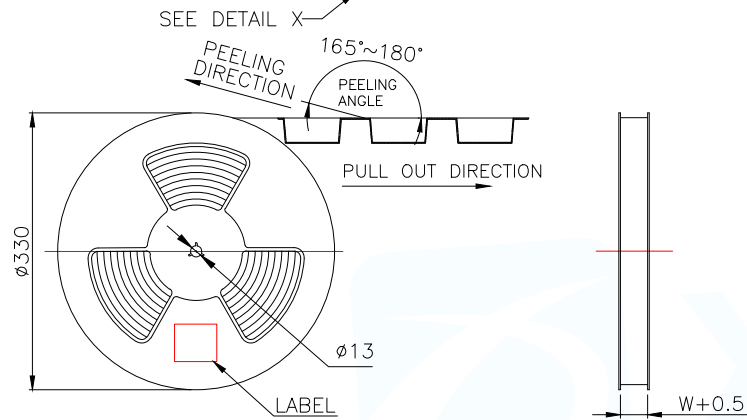
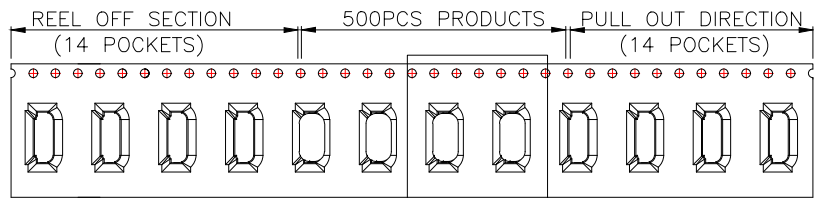

	REEL/TRAY	CARTON
CONNECTOR (PCS)	500	5000

MANUFACTURE DWG		东莞市讯普电子科技有限公司 DongGuan XunPu Electronics Co.,Ltd	
UNLESS OTHERWISE SPECIFIED TOLERANCES		TITLE: USB CF 6PIN VERTICAL SMT	
		PAR	TYPEC-251LX-ECP6
DECIMALS:		DWN	
ANGLES:		CHKD	
.X:±0.30	X':±10'	APVD	
.XX:±0.20	.X':±8"	SCALE 1:1	UNIT:MM
.XXX:±0.10	.XX':±5"	SIZE:A4	SHEET:1F1
CUSTOMER COPY			REV:A