

12	13	14	15
MAPX	MODIFICATION	DATE	APPROVE

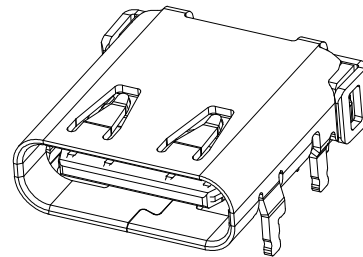

NOTE:

- 1.MATERIAL SPECIFICATION:
  - 1.HOUSING:HIGH TEMPERATURE RESISTANT PLASTIC,UL94 V-0.
  - 2.CONTACTS:COPPER ALLOY
  - 3.MID PLATE: STAINLESS STEEL
  - 4.FRONT SHELL: STAINLESS STEEL
  - 5.EMI PLATE: STAINLESS STEEL
- 2.PLATING SPECIFICATION:
  - 2-1.CONTACTS:
    - Ni 50u" MIN. UNDER PLATED OVER ALL.
    - Au PLATED ON THE FUNCTIONAL AREA OF CONTACT.
    - CONTACT FUNCTIONAL AREA PLATED : Au 3u"
    - CONTACT SOLDER AREA PLATED : Au G/F"
  - 2-2.FRONT SHELL:
    - Ni 30u" MIN. UNDER PLATED OVER ALL.
  - 2-3.MID PLATE&EMI PLATE:
    - CLEAR ONLY
- 3.MECHANICAL PERFORMANCE,
  - 3-1.INSERTION FORCE: 0.5~2.0kgf.
  - 3-2.REMOVAL FORCE: 0.8kgf~2.0kgf.
  - 3-3.DURABILITY: 10000 CYCLES.
- 4.ELECTRICAL PERFORMANCE,
  - 4-1. CURRENT RATING:5.0A  
VOLTAGE RATING:5.0V
  - 4-2. LLCR:
    - VBUS & GND PINS AND OTHER PINS: 40mA/PIN MAX.
    - SHIELD: 50mA/MAX.
    - LLCR MAX. CHANGE OF ALL PINS: 10mA.
  - 4-3.INSULATION RESISTANCE: 100MΩ MIN
  - 4-4.DIELECTRIC WITHSTAND VOLTAGE,AC 100V FOR 1 MINUTE.
5. ENVIRONMENTAL PERFORMANCE:
  - OPERATING TEMPERATURE: -40°C~+85°C.
- 6.IR REFLOW:
  - THE PEAK TEMPERATURE ON THE BOARD SHALL BE MAINTAINED FOR 10 SECONDS AT 260°C.

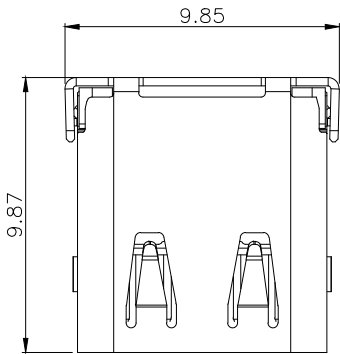
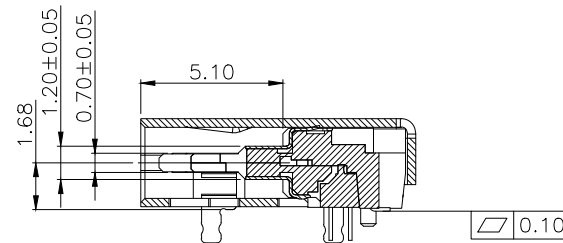
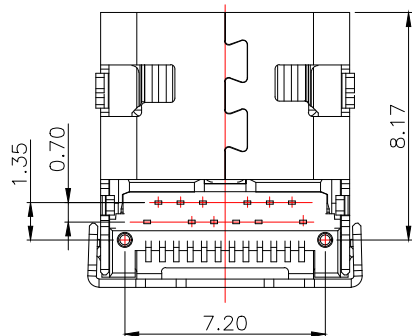
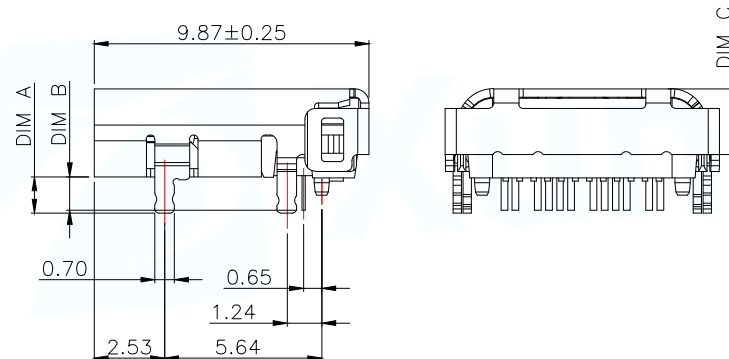
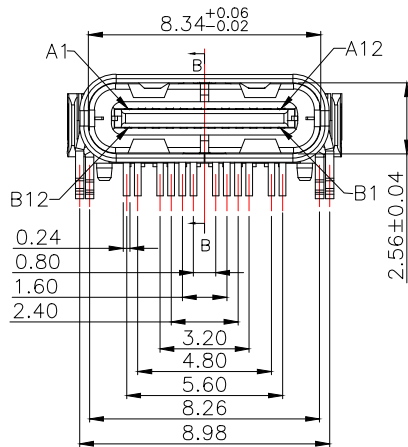

SECTION B-B  
SCALE 1:1

MANUFACTURE DWG		 东莞市讯普电子科技有限公司 DongGuan XunPu Electronics Co.,Ltd	
UNLESS OTHERWISE SPECIFIED TOLERANCES			TITLE: USB C F 24PIN DIP+SMT WITH SPRING&POST
DECIMALS:	ANGLES:		PAR TYPEC-324DBW-ACP24A
.X:±0.30	X':±10°		DWN
.XX:±0.20	.X':±8°		CHKD
.XXX:±0.10	.XX':±5°	APVD	SCALE 1:1 UNIT:MM
CUSTOMER COPY		SIZE:A4	SHEET:1F1
			REV:A

TABLE 1

ITEM	P/N	DIM"A"	DIM"B"	DIM"C"	HOUSING CLOER	PLATING	
						MATING AREA	SOLDER AREA
1	TYPEC-324DBW-ACP24A	1.30	1.20	1.96	BALCK	Au:3u"	Au:G/F
2	TYPEC-324DBW-ACP24B	1.55	1.45	2.36		Au:15u"	Au:G/F
3					NATURAL	Au:3u"	Au:G/F
4					BALCK	Au:30u"	Au:G/F
5							
6							
7							

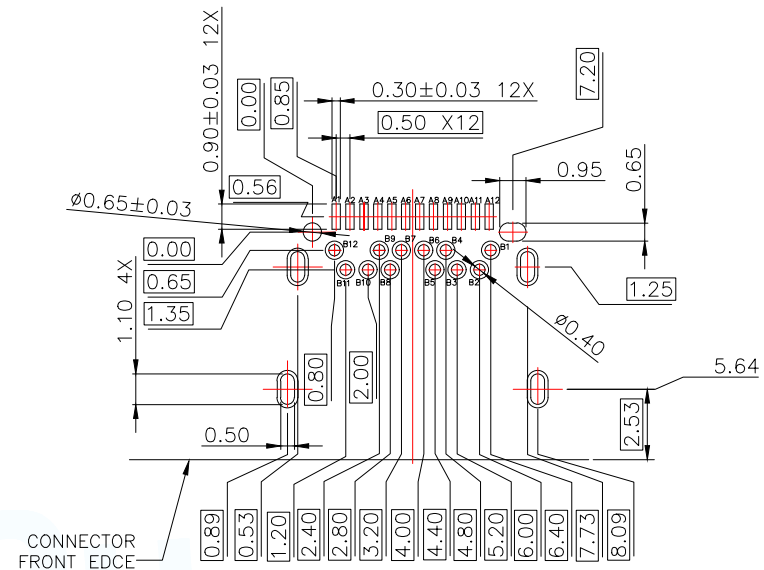

USB TYPE-C PIN ASSIGNMENTS

PIN NUMBER	SIGNAL NAME	PIN NUMBER	SIGNAL NAME
A1	GND	B12	GND
A2	SSTXp1+	B11	SSRXp1+
A3	SSTXn1-	B10	SSRXn1-
A4	Vbus	B9	Vbus
A5	CC1	B8	SBU2
A6	Dp1	B7	Dn2
A7	Dn1	B6	Dp2
A8	SBU1	B5	CC2
A9	Vbus	B4	Vbus
A10	SSRXn2-	B3	SSTXn2-
A11	SSRXp2+	B2	SSTXp2+
A12	GND	B1	GND

RECOMMENDED P.C.B. LAYOUT (T=1.00mm)  
TOLERANCE UNSPECIFIED ±0.05mm

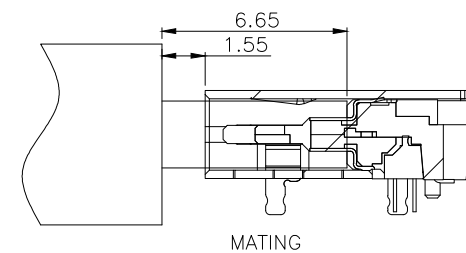

MANUFACTURE DWG		 东莞市讯普电子科技有限公司 DongGuan XunPu Electronics Co.,Ltd	
UNLESS OTHERWISE SPECIFIED TOLERANCES			TITLE: USB C F 24PIN DIP+ SMT WITH SPRING&POST
DECIMALS:	ANGLES:		PAR TYPEC-324DBW-ACP24A
.X:±0.30	X':±10'		DWN
.XX:±0.20	.X':±8'		CHKD
.XXX:±0.10	.XX':±5'	APVD	SCALE 1:1 UNIT:MM
CUSTOMER COPY		SIZE:A4	SHEET:1F1
			REV:A

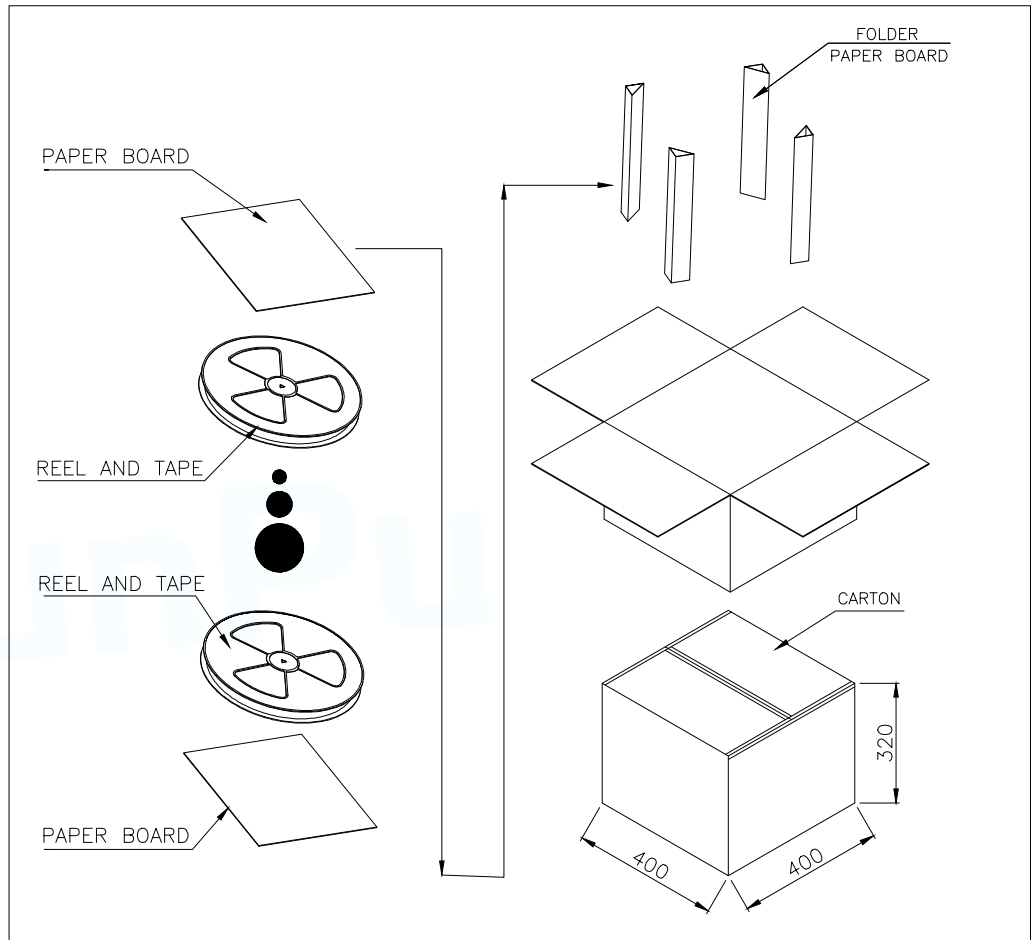
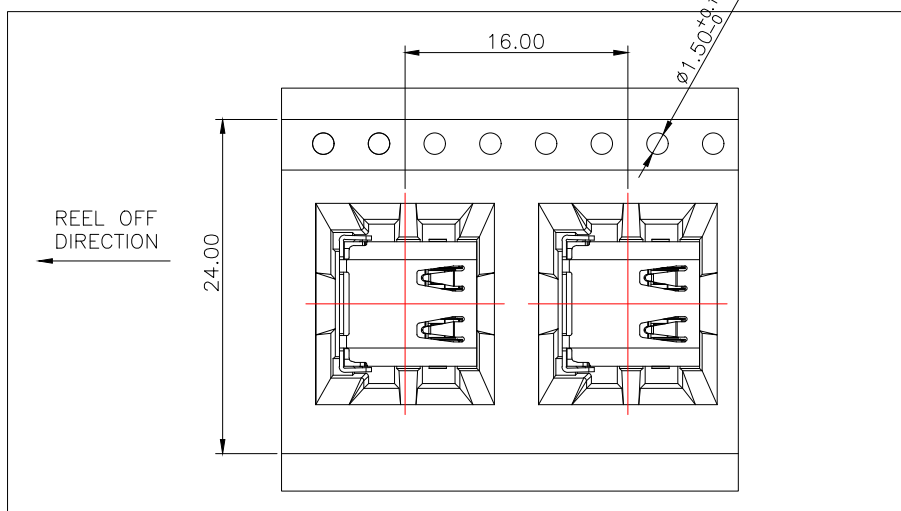
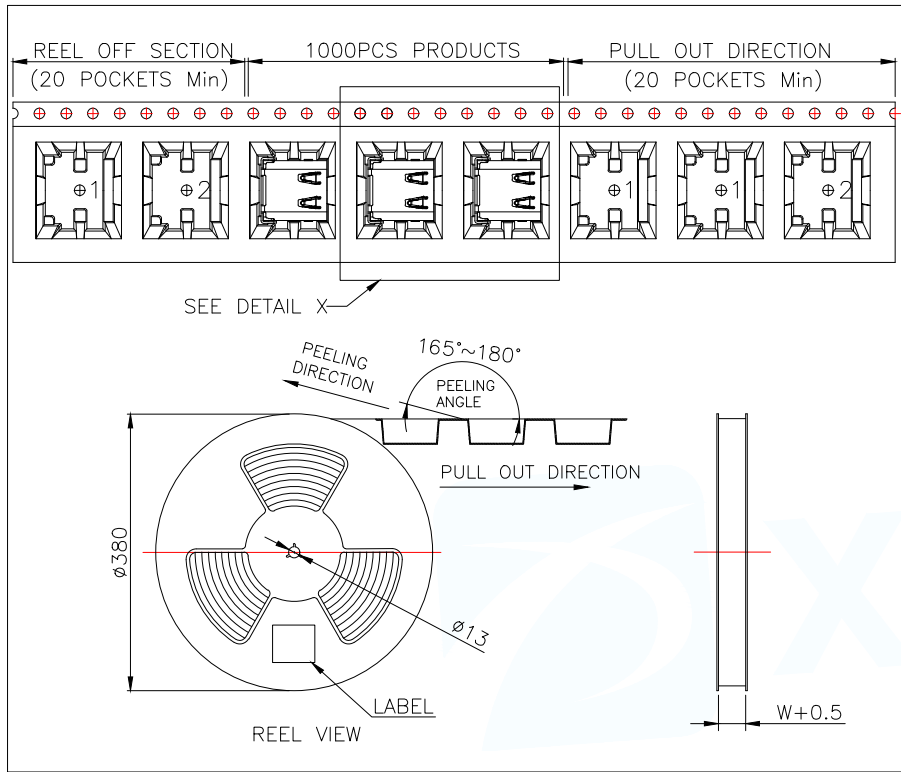

	REEL/TRAY	CARTON
CONNECTOR (PCS)	1000	10000

MANUFACTURE DWG		 东莞市讯普电子科技有限公司 DongGuan XunPu Electronics Co.,Ltd	
UNLESS OTHERWISE SPECIFIED TOLERANCES		TITLE: USB C F 24PIN DIP+SMT WITH SPRING&POST PAR TYPEC-324DBW-ACP24A	
DECIMALS:	ANGLES:	DWN	
.X:±0.30	X':±10°	CHKD	
.XX:±0.20	.X':±8°	APVD	
.XXX:±0.10	.XX':±5°	SCALE:1:1	UNIT:MM
		CUSTOMER COPY	SIZE:A4
			SHEET:1F1
			REV:A