

- NOTE:
- 1.MATERIAL SPECIFICATION:
 - 1.HOUSING:HIGH TEMPERATURE RESISTANT PLASTIC,UL94 V-0.(PA9T)
 - 2.CONTACTS:COPPER ALLOY(C1815)
 - 3.MID PLATE: STAINLESS STEEL(SUS301)
 - 4.FRONT SHELL: STAINLESS STEEL(SUS304)
 - 5.EMI PLATE: STAINLESS STEEL(SUS304)
 - 2.PLATING SPECIFICATION:
 - 2-1.CONTACTS:
 - Ni 50u" MIN. UNDER PLATED OVER ALL.
 - Au PLATED ON THE FUNCTIONAL AREA OF CONTACT.
 - CONTACT FUNCTIONAL AREA PLATED : Au G/F
 - CONTACT SOLDER AREA PLATED : Au G/F
 - 2-2.FRONT SHELL:
 - Ni 30u" MIN. UNDER PLATED OVER ALL.
 - 2-3.MID PLATE&EMI PLATE:
 - CLEAR ONLY
 - 3.MECHANICAL PERFORMANCE,
 - 3-1.INSERTION FORCE: 0.5~2.0kgf.
 - 3-2.REMOVAL FORCE: 0.8kgf~2.0kgf.
 - 3-3.DURABILITY: 10000 CYCLES.
 - 4.ELECTRICAL PERFORMANCE,
 - 4-1. CURRENT RATING:5.0A
VOLTAGE RATING:5.0V
 - 4-2. LLCR:
 - VBUS & GND PINS AND OTHER PINS: 40mA/PIN MAX.
 - LLCR MAX. CHANGE OF ALL PINS: 10mA.
 - 4-3.INSULATION RESISTANCE: 100MΩ MIN
 - 4-4.DIELECTRIC WITHSTAND VOLTAGE,AC 100V FOR 1 MINUTE.
 5. ENVIRONMENTAL PERFORMANCE:
 - OPERATING TEMPERATURE: -40°C~+85°C.
 - 6.IR REFLOW:
 - THE PEAK TEMPERATURE ON THE BOARD SHALL BE MAINTAINED FOR 10 SECONDS AT 260°C.

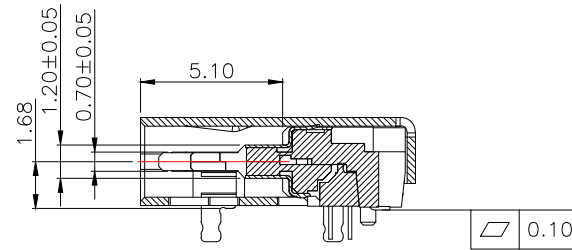

SECTION B-B
SCALE 1:1

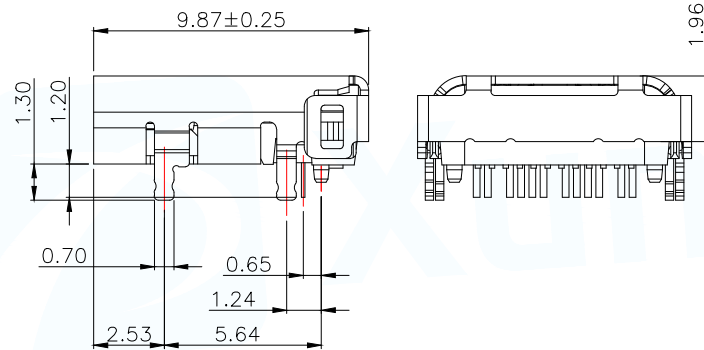
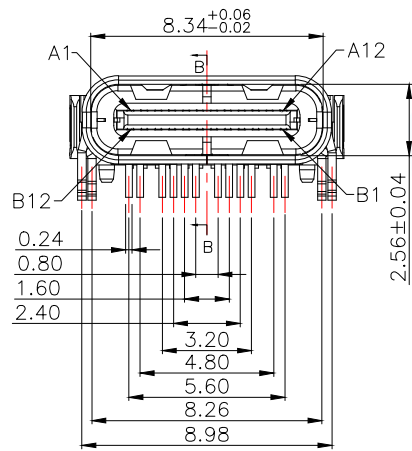
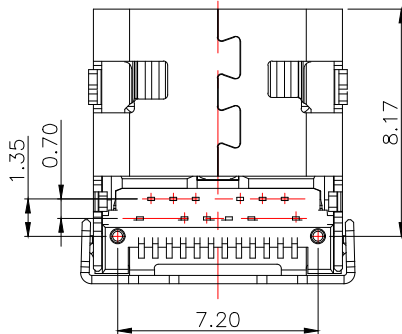

MANUFACTURE DWG		东莞市讯普电子科技有限公司 DongGuan XunPu Electronics Co.,Ltd	
UNLESS OTHERWISE SPECIFIED TOLERANCES			TITLE: USB C F 24PIN DIP+SMT WITH SPRING&POST
DECIMALS:	ANGLES:		PAR TYPEC-324-BCP24
.X:±0.30	X':±10°		DWN
.XX:±0.20	.X':±8°		CHKD
.XXX:±0.10	.XX':±5°	APVD	SCALE 1:1 UNIT:MM
CUSTOMER COPY		SIZE:A4	SHEET:1F1
			REV:A

USB TYPE-C PIN ASSIGNMENTS

PIN NUMBER	SIGNAL NAME	PIN NUMBER	SIGNAL NAME
A1	GND	B12	GND
A2	TXp1+	B11	RXp1+
A3	TXn1-	B10	RXn1-
A4	Vbus	B9	Vbus
A5	CC1	B8	SBU2
A6	Dp1	B7	Dn2
A7	Dn1	B6	Dp2
A8	SBU1	B5	CC2
A9	Vbus	B4	Vbus
A10	RXn2-	B3	TXn2-
A11	RXp2+	B2	TXp2+
A12	GND	B1	GND

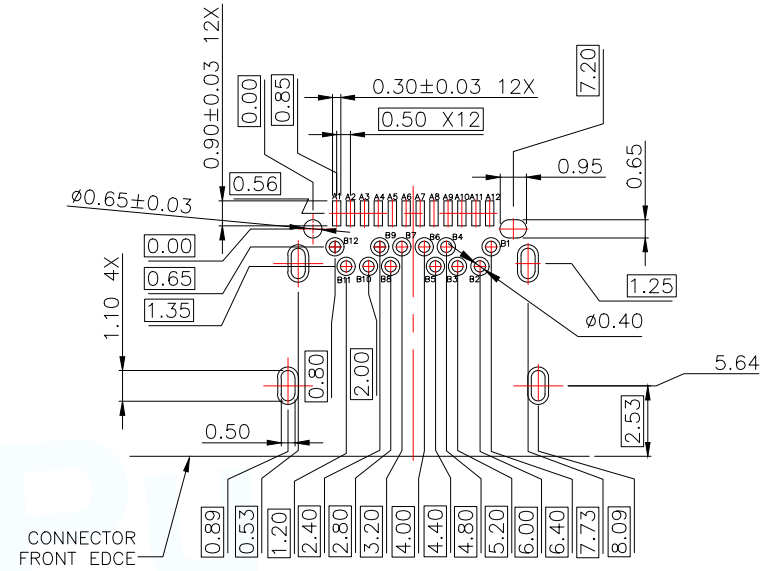

RECOMMENDED P.C.B. LAYOUT (T=1.00mm)
TOLERANCE UNSPECIFIED ±0.05mm

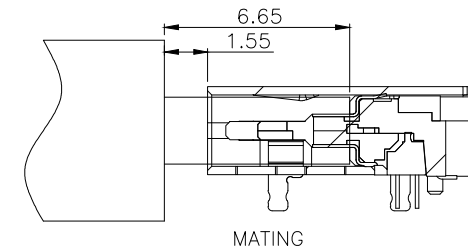

MANUFACTURE DWG		 东莞市讯普电子科技有限公司 DongGuan XunPu Electronics Co.,Ltd	
UNLESS OTHERWISE SPECIFIED TOLERANCES		TITLE: USB C F 24PIN DIP+SMT WITH SPRING&POST PAR TYPEC-324-BCP24 DWN CHKD APVD SCALE 1:1 UNIT:MM SIZE:A4 SHEET:1F1	
DECIMALS:	ANGLES:		
.X:±0.30	X':±10°		REV:A
.XX:±0.20	.X':±8°		
.XXX:±0.10	.XX':±5°		
CUSTOMER COPY			

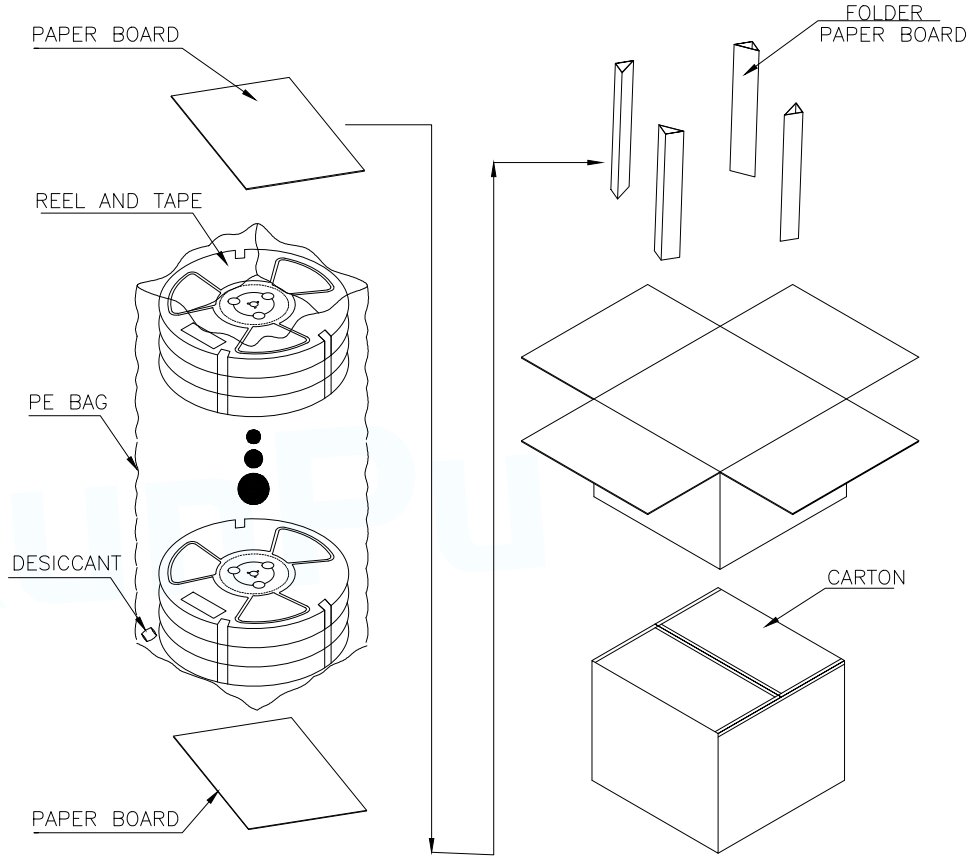
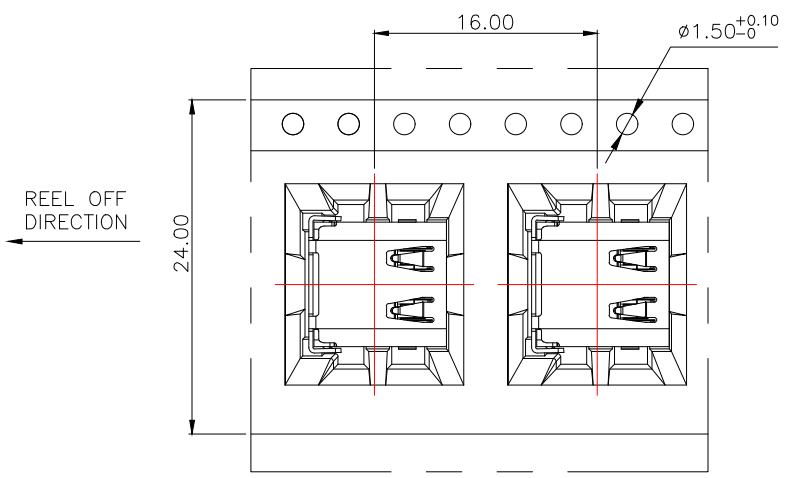
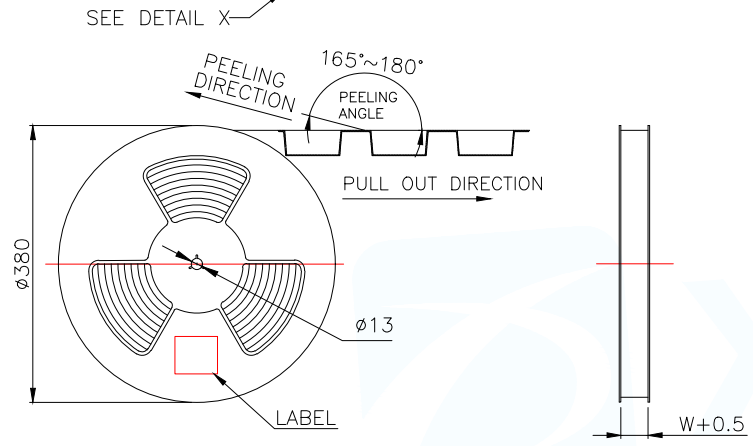
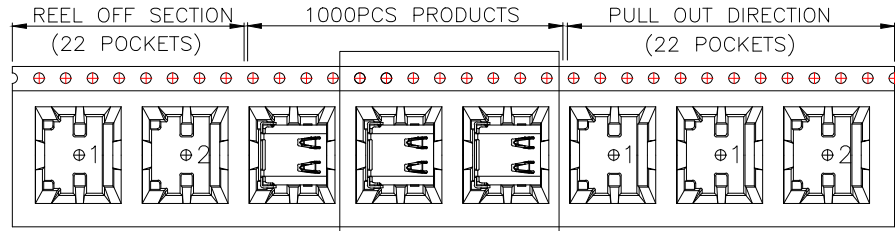

	REEL/TRAY	CARTON
CONNECTOR (PCS)	1000	10000

MANUFACTURE DWG		 东莞市讯普电子科技有限公司 DongGuan XunPu Electronics Co.,Ltd	
UNLESS OTHERWISE SPECIFIED TOLERANCES		TITLE: USB C F 24PIN DIP+SMT WITH SPRING&POST PAR TYPEC-324-BCP24	
DECIMALS:	ANGLES:	DWN	
.X:±0.30	X':±10°	CHKD	
.XX:±0.20	.X':±8°	APVD	
.XXX:±0.10	.XX':±5°	SCALE 1:1	UNIT:MM
CUSTOMER COPY		SIZE:A4	SHEET:1F1
			REV:A