

SPECIFICATIONS:

- ELECTRICAL CHARACTERISTICS
 - CONTACT RESISTANCE: 80 MILLIOHMS MAX.
 - INSULATION RESISTANCE: 1,000 MEGOHMS MIN.
 - DIELECTRIC WITHSTANDING VOLTAGE: 500V AC FOR 1 MINUTE.
- MECHANICAL CHARACTERISTICS
 - RETENTION FORCE: MIN.100GF/PIN
 - DURABILITY: 5,000 CYCLES
- ROHS 2002/95/EC COMPLIANT.

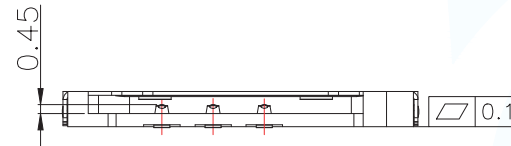

MINI SIM CARD	
Pin No.	NAME
C1	VCC OF SIM
C2	RST OF SIM
C3	CLK OF SIM
C5	GND OF SIM
C6	VPP OF SIM
C7	I/O OF SIM
C4/C8	N/A

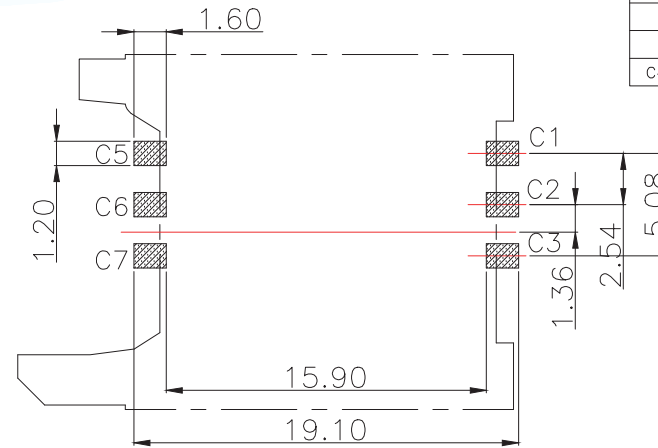
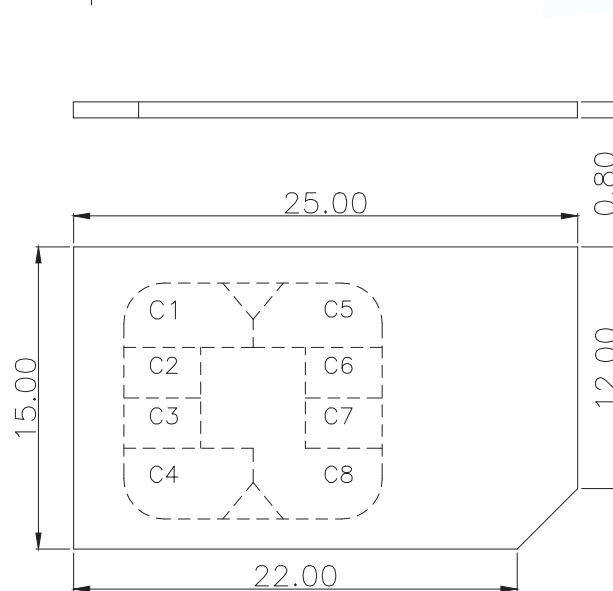
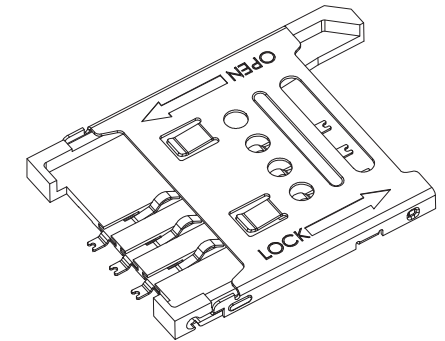

PAD AREA
 KEEP OUT AREA

RECOMMENDED PCB LAYOUT
 GENERAL TOLERANCE ± 0.05

NO	DESCRIPTION	QTY	MATERIAL	PLATING & COLOR
C	SHELL	1	STAINLESS STEEL 0.20t	Ni PLATING
B	CONTACT	6	COPPER ALLOY 0.15t	Gold plated on contact area Tin plated on Solder tail All over Nickel Plated
A	HOUSING	1	HIGH-TEMPERATURE PLASTIC UL94-V0	BLACK

MANUFACTURE DWG		东莞市讯普电子科技有限公司 DongGuan XunPu Electronics Co.,Ltd	
UNLESS OTHERWISE SPECIFIED TOLERANCES		TITLE:MINI SIM CARD HINGED 6P TYPE 1.8H	
DECIMALS:	ANGLES:	PAR	SIM-106-ARP6
X.: ± 0.50	X':: $\pm 2'$	DWN	
X.X: ± 0.30	X.X':: $\pm 1'$	CHKD	
X.XX: ± 0.20		APVD	
CUSTOMER COPY		SCALE:1:1	UNIT:MM
		SIZE:A4	SHEET:1F1
			REV:A



<Figure 1>

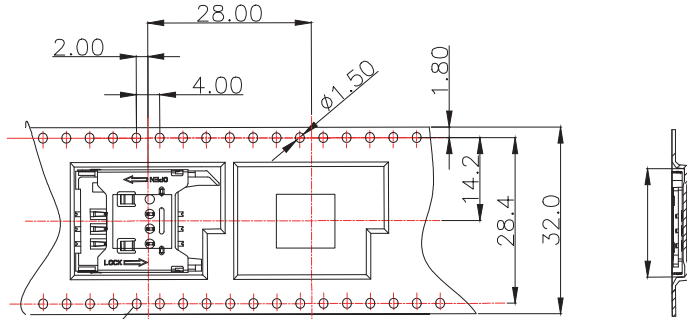

<TABLE 1> PACKAGING QUANTITY

QTY/REEL	REEL/CARTON	QTY/CARTON
880	8	7040
Net weight/CARTON:		5.85Kg
Gross weight/CARTON:		10.9Kg

<Figure 3>

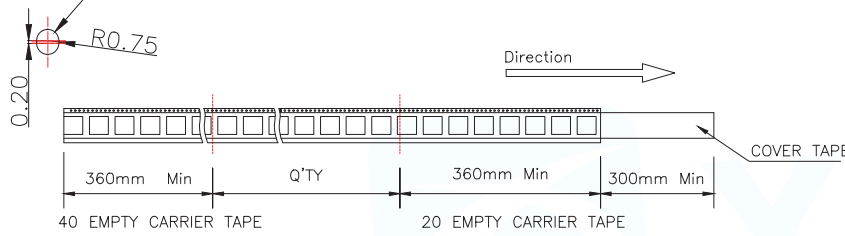
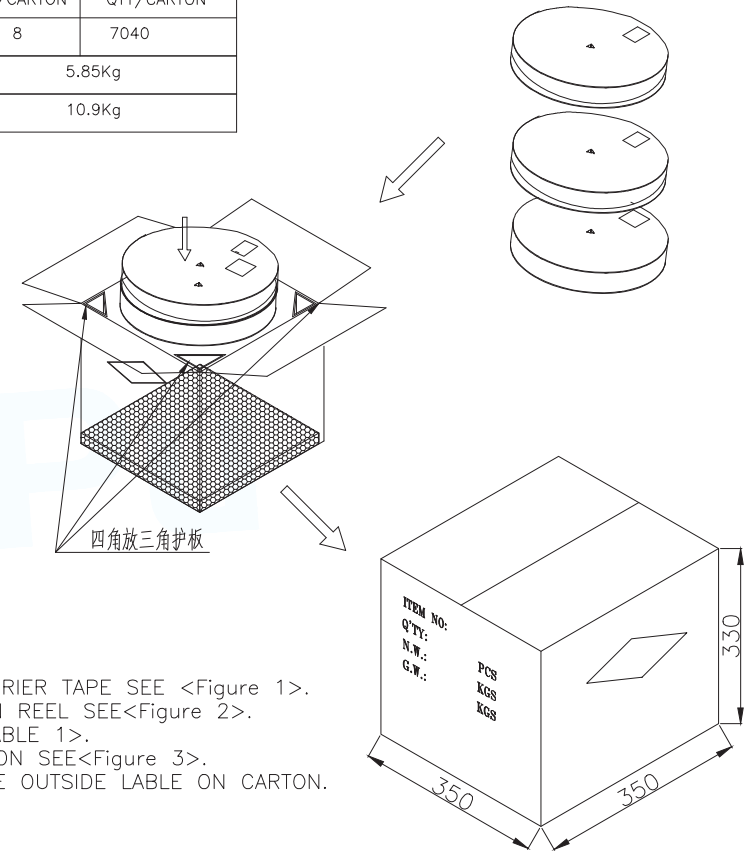

<Figure 2>

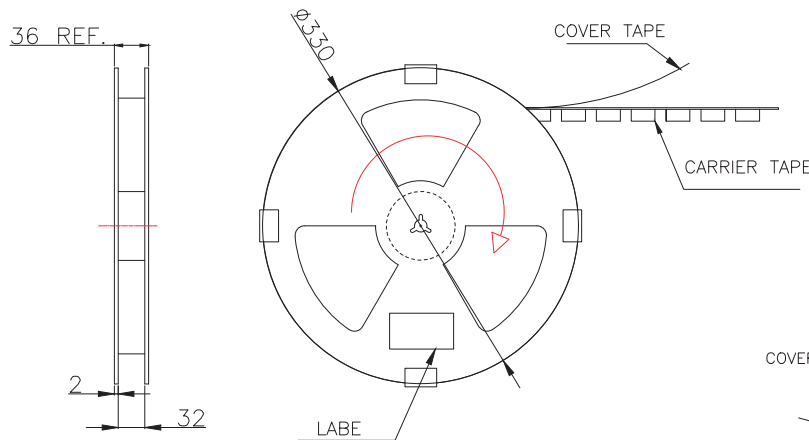

NOTE:

- 1.PUT THE PRODUCT IN CARRIER TAPE SEE <Figure 1>.
- 2.PUT THE INSIDE LABLE ON REEL SEE<Figure 2>.
- 3.PACKING QUANTITY SEE <TABLE 1>.
- 4.PUT THE REEL INTO CARTON SEE<Figure 3>.
- 5.SEALING BOX,AND PUT THE OUTSIDE LABLE ON CARTON.

COVER TAPE PEELING FORCE:20gf~120gf

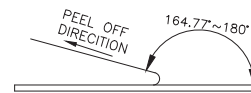

MANUFACTURE DWG		 东莞市讯普电子科技有限公司 DongGuan XunPu Electronics Co.,Ltd	
UNLESS OTHERWISE SPECIFIED TOLERANCES			TITLE:MINI SIM CARD HINGED 6P TYPE 1.8H 包装图
DECIMALS:	ANGLES:		PAR
X.: ± 0.50	X.': $\pm 2'$		SIM-106-ARP6
X.X: ± 0.30	X.X': $\pm 1'$		DWN
X.XX: ± 0.20		CHKD	APVD
CUSTOMER COPY		SCALE:1:1	UNIT:MM
		SIZE:A4	UNIT:MM
		SHEET:1F1	REV:A